

**"Highest Performance  
Lowest Price"**

**Microsoft**  
**GOLD CERTIFIED**  
Partner

# **GFI** WHITE PAPER

## **Sending faxes in real-time over an IP network**

### **How to benefit from Fax over Internet Protocol (FoIP) to send faxes**

This technical white paper gives an introduction to fax over Internet Protocol (FoIP) and explains the various usages and advantages of FoIP. FoIP can also be used to implement Least Cost Routing (LCR); this results in cost-effectiveness that is achieved through a reduction in international calls dialed (since calls are translated into a local call at the recipient's country).



### **Sign up to GFI's FREE SMB-Zone Newsletter**

Receive FREE invites to SMB focused content such as IT Advice,  
Topical White Papers, MVP Tips and Tricks, Webcasts and much more!



# Sending faxes in real-time over an IP network

## Introduction

Faxing manually is out of date! The time when faxes used to be sent one by one over a public switched telephone network (PSTN) or Integrated Services Digital Network (ISDN) network is gone. Using Internet technology it is possible to send professional faxes over the Internet at a very low cost. This can be achieved through Fax over Internet Protocol (FoIP) which is a technology that allows faxes to be sent in real-time over an IP network.

This white paper examines the different technologies and protocols available to send faxes.

- Introduction..... 2
- What is FoIP? ..... 2
- The fax session..... 3
- Possibility of Fax over VoIP audio ..... 4
- Calling a third party with VoIP ..... 4
- Least cost routing ..... 7
- SIP and H.323 session management..... 8
- What is H.323?..... 9
- What is SIP? ..... 10
- FAXmaker and Fax over IP (FoIP) ..... 12
- About GFI..... 13

## What is FoIP?

FoIP is a deviation from voice over Internet Protocol (VoIP) as it makes use of a new protocol (T.38) instead of a voice codec. However, both VoIP and FoIP have session management features in common in that both have connection, disconnection and negotiation stages. In VoIP the data is audio and is sent over an audio compression codec for example G.117a which is a lossy compression scheme: a compression method whereby data that is compressed and then decompressed may well be different from the original, but is "close enough" to be useful in some way. In FoIP the data is T.30 fax data instead of audio and T.30 data does not make use of a lossy compression scheme. Since T.30 data is quite compressed in itself, there is no need for compression but mostly data integrity, and as illustrated in the diagram below, FoIP uses a protocol called T.38 to transfer fax data over IP.

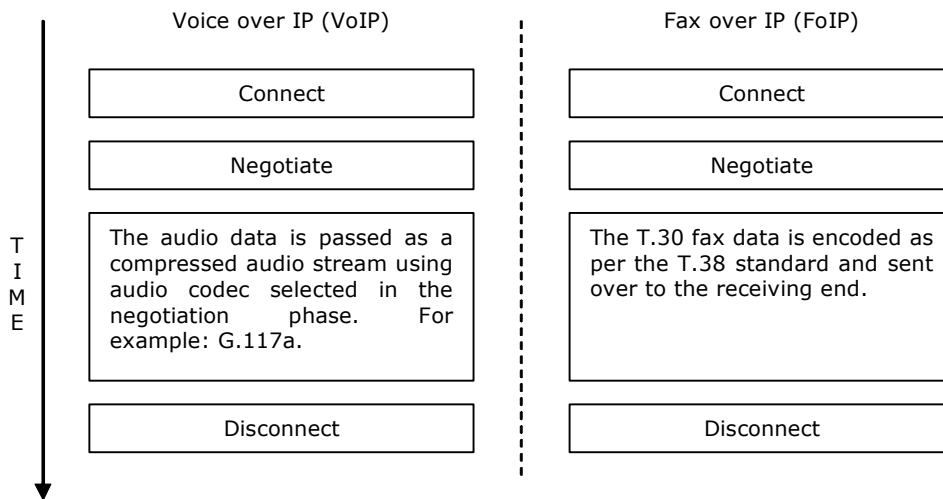

Format of the data passed from sender to receiver in VoIP and FoIP

## The fax session

A fax session is a standardized way of transferring images via a communications medium in real-time. The real-time element is necessary to confirm the transfer of the images. Nowadays, this confirmation in conjunction with Error Correct Mode (ECM) makes a fax legally binding and is used for legal reasons.

Standardized fax data is called T.30. This data is the same for all types of fax sessions with the difference being that it is encoded in various ways depending on the communications medium used. The following illustrates a typical fax session over analog public switched telephone network (PSTN) telephone lines:

In the illustrations below, the communications medium used is analog PSTN telephone lines. These can only send audible data in the range of just below 4 KHz which is only good for voice. The T.30 fax data is encoded to audible data, sent to the recipient, decoded back to T.30 data and thus resulting in an image at the recipient's side.



# Sending faxes in real-time over an IP network

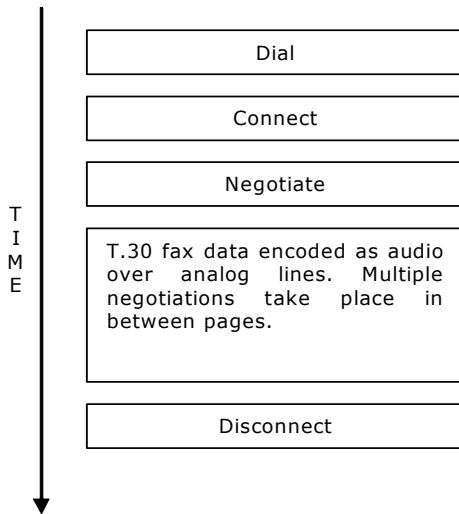

*Fax session over analog PSTN lines*

## Possibility of Fax over VoIP audio

It is possible to send a fax of normal audio VoIP but the success rates are very low. This method is referred to as **Fax over Voice over IP**.

VoIP uses a lossy codec that humans hear correctly. This codec eliminates certain parts of the audio that our ear cannot hear for further compression. To reduce the bandwidth used by the codec for audio data, silence is also not transmitted as part of the audible data. To make things worse, some VoIP codecs produce what is called 'comfort noise' so that the human caller hears silence as soothing noise. Fax machines do not like comfort noise since they can 'hear' better than humans do and need the audible data intact including the silent parts and also the non-human-audible parts. Therefore, in general Fax over Voice over IP is not a good option and will surely fail miserably.

## Calling a third party with VoIP

There are many ways to call a third party using VoIP and all these methods are also relevant for FoIP. The various methods are described below.

### Direct IP

This is a different methodology from normal phone numbers. As the name 'Direct IP' implies, this method requires the exact IP address or URL of the third party to be known despite its impracticality.

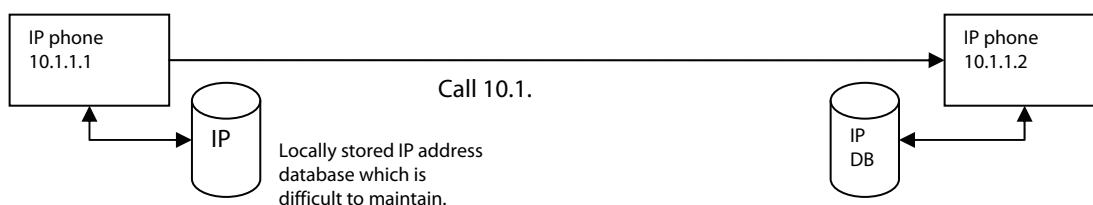

*The Direct IP method*

## Using a Registrar/Gatekeeper

This method builds on the Direct IP method described above, however, since IP addresses are not very easy to remember, it makes use of regular phone numbers to call a third party using VoIP. This method uses a Registrar (SIP) or a Gatekeeper (H.323), where both Registrar and Gatekeeper perform the same task but called differently depending on the protocol used.

This method works by registering both IP address and phone number with the Registrar or Gatekeeper. When a third party needs to be called, it is then sufficient to dial the phone number of the third party only and the Registrar or Gatekeeper are then queried for the IP address of the specific phone number to call.

The following examples describe the process:

- 1 Phone 10.1.1.1 registers with server having phone number 123
- 2 Phone 10.1.1.2 registers with server having phone number 456
- 3 Phone 10.1.1.1 needs to call phone number 456 so it queries the server for the IP address of the phone number 456.
- 4 The server replies saying that phone number 456 has IP 10.1.1.2
- 5 Phone 10.1.1.1 calls 10.1.1.2 directly.
- 6 The above steps are all done transparently from the user by the phone or VoIP application.

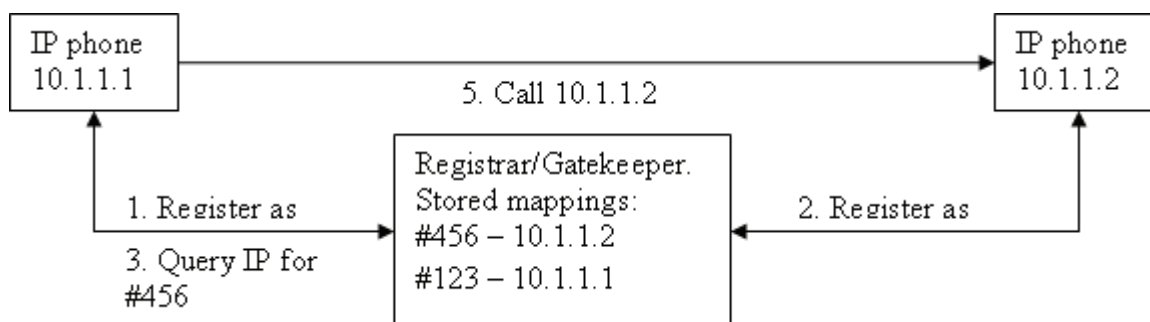

The drawback of this method is that all IP phones must be registered with the same network of Registrars or Gatekeepers to be able to resolve to the phone number.

## Gateway mode

So far, both Direct IP and Registrar/Gatekeeper methods assumed that the recipient is on a VoIP network. However, some third parties might only have a normal land line having PSTN or ISDN. There are two ways of contacting third parties on a normal landline, either by using a VoIP provider or by setting up your own gateway network.

### VoIP provider

This method is very common nowadays especially for low cost international calls. Normally the VoIP provider sets up an IP phone (or normal phone connected to an Internet router) in your premises. You are also assigned a phone number. With this equipment you can call a normal landline or IP number directly by dialing only the recipient's phone number. The VoIP provider will then find the best route to call the third party with the least cost possible.

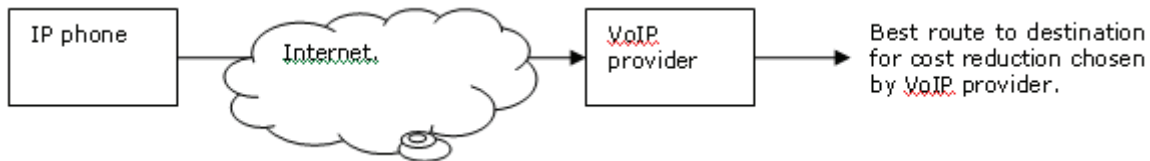

This is the simplest and most straightforward form of dialing to a landline or internationally using VoIP. The greatest drawback is that the VoIP provider must also support FoIP to be able to make fax calls using FoIP capable equipment.

### Building your own gateway network

This method is preferred in larger companies, especially those that have an existing IP infrastructure. Building a gateway network involves the use of VoIP Gateways. These devices change transport medium in real-time. For example an IP call is converted and passed through a PSTN line. To better describe this system we need to understand some technical jargon.

- **Terminal Endpoint (TE)** – This is the starting or ending point of an IP call. For example, an IP phone or a VoIP application on your computer.
- **Gateway (GW)** – This can act as both a TE and a tunnel to transfer data where a normal TE is not capable of. For example from IP to ISDN.

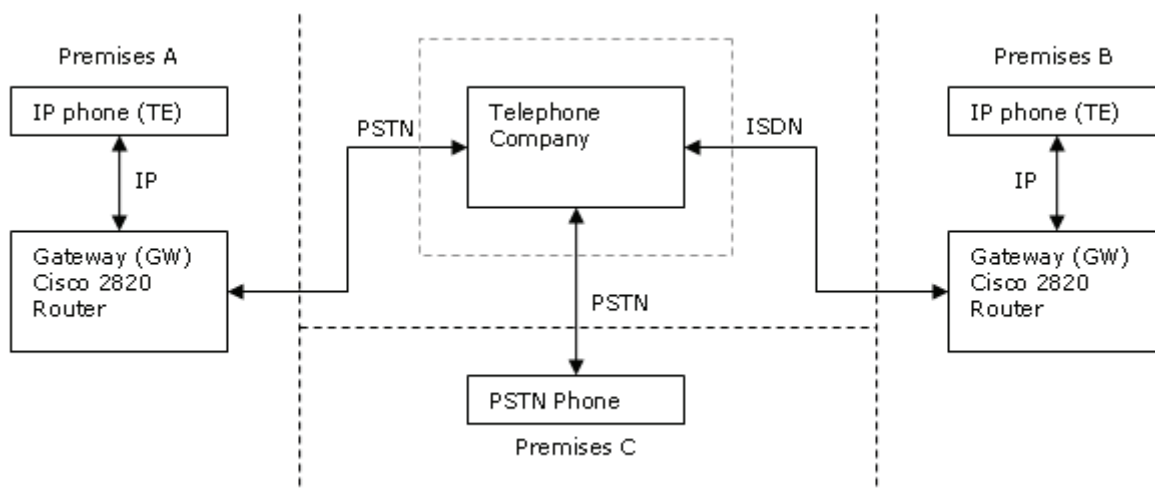

As illustrated in the above diagram, premises A and B have an IP gateway that translates the PSTN/ISDN calls to IP and vice versa while premises C only have normal PSTN lines. If premises A wish to call premises C, at face value, a caller from premises A simply has to dial the number of premises C. Under the hood, the following would be happening:

- 1 The caller from premises A dials the number at premises C.
- 2 The Gateway at premises A gets the number and depending on its internal dialing rules can either transfer to another internal IP phone connected to it or dial the number out to the telephone company. In the meantime, the caller device is waiting from the gateway.
- 3 A rule in the gateway is triggered to call the telephone company. The number of premises C is called and so the PSTN phone at premises C rings.
- 4 When the phone at premises C is picked up, the gateway at premises A knows this and so establishes an IP call between itself and the caller and between itself and the telephone company, thus translating from PSTN to IP and vice versa.

The same steps above are also used to call someone at premises B. The reverse of what the gateway does at premises A is done at premises B to establish a call between a caller from premises A and a receiver at premises B.

Other examples of gateway devices are PABXs that are IP-enabled thus having an existing Ethernet connection to connect to an existing IP infrastructure.

### Least cost routing

International companies can benefit when they build their own gateway by considering least cost routing.

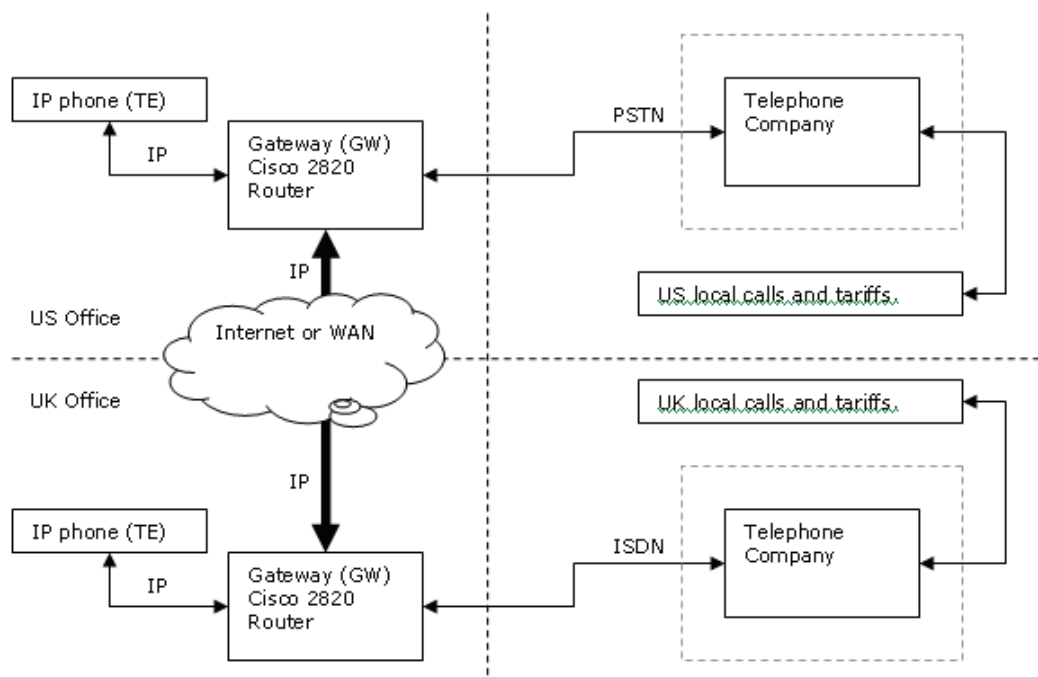

It is well known that calls from one country to another (example from a US office to the UK office) are more costly than calls within the same country. However, through FOIP it is possible to implement Least Cost Routing (LCR). This results in cost-effectiveness that is achieved through a reduction in international calls dialed since calls are translated into a local call at the recipient's country.

### Notes about this method

Some companies have a server room which is distant from the connection room for various reasons. These companies cannot have a server connected directly to the ISDN or PSTN connections but they only have an IP network in the server room.

To solve this issue, this company has to install a VoIP gateway in the connection room to translate from ISDN/PSTN to IP and vice versa so that the server room can have access to the ISDN/PSTN connections via VoIP.

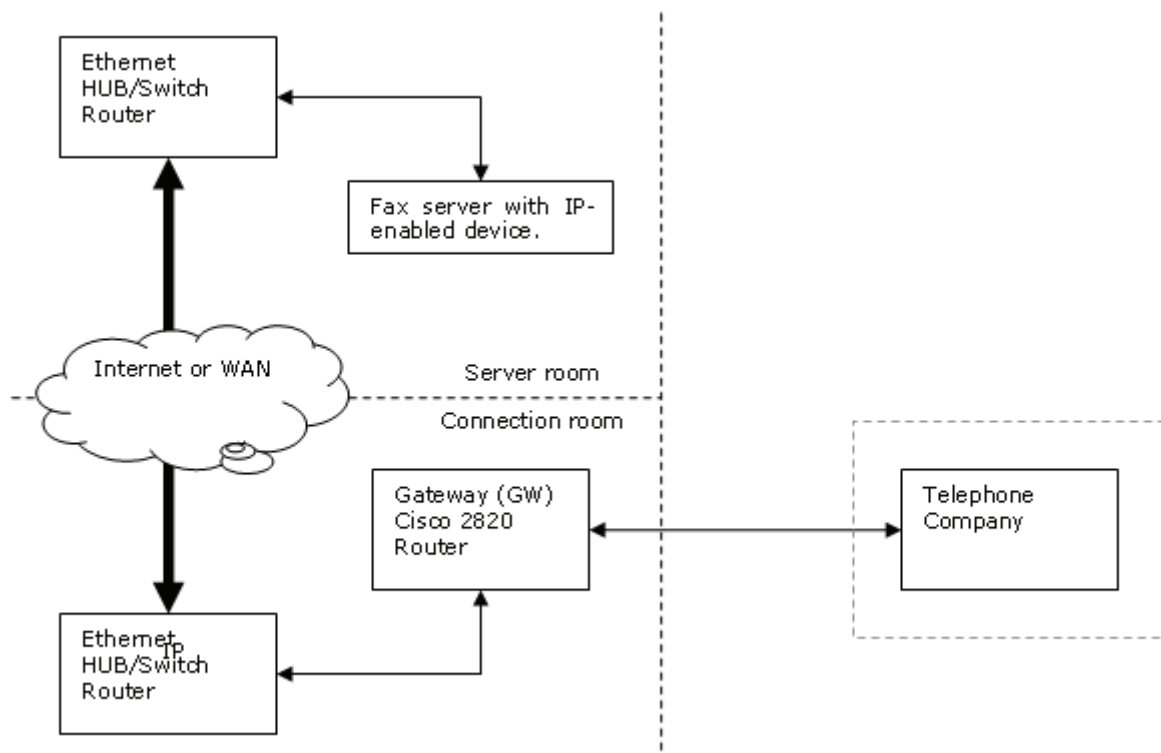

### SIP and H.323 session management

SIP and H.323 are session management protocols, or rather a collection of protocols used throughout the IP session. Both SIP and H.323 are session control protocols for VoIP and only setup the session. Either SIP or H.323 can be used, but only one at a time for example if SIP is used to connect, SIP has to be used to disconnect.



For example:

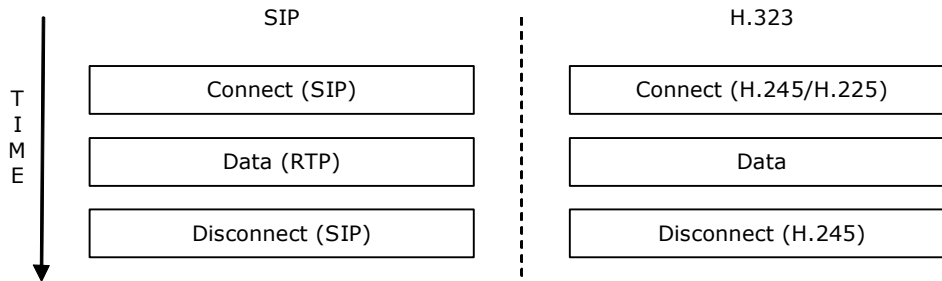

## What is H.323?

H.323 is an umbrella recommendation from the ITU-T, which defines the protocols to provide audio-visual communication sessions on any packet network. It is currently implemented by various internet real-time applications such as NetMeeting and GnomeMeeting (the latter using the OpenH323 implementation). It is a part of the H.32x series of protocols which also address communications over ISDN, PSTN or SS7. H.323 is commonly used in Voice over IP (VoIP, Internet Telephony, or IP Telephony) and IP-based videoconferencing ([www.wikipedia.com](http://www.wikipedia.com)).

H.323 was originally created to provide a mechanism for transporting multimedia applications over LANs but it has rapidly evolved to address the growing needs of VoIP networks. The strength of H.323 was the relatively early availability of a set of standards, not only defining the basic call model, but in addition the supplementary services, needed to address business communication expectations. H.323 was the first VoIP standard to adopt the IETF standard RTP to transport audio and video over IP networks.

H.323 is based on the ISDN Q.931 protocol and is suited for interworking scenarios between IP and ISDN, respectively between IP and QSIG. A call model, similar to the ISDN call model, eases the introduction of IP Telephony into existing networks of ISDN based PBX systems. In simple terms, within the context of H.323, an IP based PBX is a Gatekeeper plus supplementary services.

H.323 references many other ITU-T protocols like:

- H.225.0 protocol is used to describe call signaling, the media (audio and video), the stream, media stream synchronization and control message formats.
- H.245 control protocol for multimedia communication, describes the messages and procedures used for opening and closing logical channels for audio, video and data, capability exchange, control and indications.
- H.450 describes the Supplementary Services.
- H.235 describes security in H.323.
- H.239 describes dual stream use in videoconferencing, usually one for live video, the other for presentation.



## Sending faxes in real-time over an IP network

### What is SIP?

Session Initiation Protocol (SIP) is a protocol developed by the IETF MMUSIC Working Group and proposed standard for initiating, modifying, and terminating an interactive user session that involves multimedia elements such as video, voice, instant messaging, online games, and virtual reality. In November 2000, SIP was accepted as a 3GPP signaling protocol and permanent element of the IMS architecture. It is one of the leading signaling protocols for Voice over IP, along with H.323 ([www.wikipedia.com](http://www.wikipedia.com)).

A goal for SIP was to provide a superset of the call processing functions and features present in the public switched telephone network (PSTN). As such, features that permit familiar telephone-like operations are present: dialing a number, causing a phone to ring, hearing ring-back tones or a busy signal. Implementation and terminology are different.

SIP also implements many of the more advanced call processing features present in Signaling System 7 (SS7), though the two protocols themselves could hardly be more different. SS7 is a highly centralized protocol, characterized by highly complex central network architecture and dumb endpoints (traditional telephone handsets). SIP is a peer-to-peer protocol. It requires only a very simple (and thus highly scalable) core network with intelligence distributed to the network edge, embedded in endpoints (terminating devices built in either hardware or software). Many SIP features are implemented in the communicating endpoints as opposed to traditional SS7 features, which are implemented in the network. Although many other VoIP signaling protocols exist, SIP is characterized by its proponents as having roots in the IP community rather than the telecom industry. SIP has been standardized and governed primarily by the IETF while the H.323 VoIP protocol has been traditionally more associated with the ITU. However, the two organizations have endorsed both protocols in some fashion.

SIP works in concert with several other protocols and is only involved in the signaling portion of a communication session. SIP acts as a carrier for the Session Description Protocol (SDP), which describes the media content of the session, e.g. what IP ports to use, the codec being used etc. In typical use, SIP "sessions" are simply packet streams of the Real-time Transport Protocol (RTP). RTP is the carrier for the actual voice or video content itself.

The first proposed standard version (SIP 2.0) was defined in RFC 2543. The protocol was further clarified in RFC 3261, although many implementations are still using interim draft versions. Note that the version number remains 2.0.

SIP is similar to HTTP and shares some of its design principles: It is human readable and request-response structured. SIP proponents also claim it to be simpler than H.323. However, some would counter that while SIP originally had a goal of simplicity, in its current state it has become as complex as H.323. SIP shares many HTTP status codes, such as the familiar '404 not found'. The promoters of SIP have said that the rapid innovation and application development that has characterized the Web will now mark the telephony industry, too. SIP and H.323 are not limited to voice communication but can mediate any kind of communication session from voice to video or future, unrealized applications.

Hardware endpoints, devices with the look, feel, and shape of a traditional telephone, but that use SIP and RTP for communication, are commercially available from several vendors. Some of these can use Electronic Numbering (ENUM) to translate existing phone numbers to SIP addresses using DNS, so calls to other SIP users can bypass the telephone network, even though your service provider might normally act as a gateway to the PSTN network for traditional phone numbers (and charge you for it).

Today, software SIP endpoints are common. Microsoft Windows Messenger uses SIP and in June, 2003, Apple Computer announced, and released in public beta, iChat AV, a new version of their AOL Instant Messenger compatible client that supports audio and video chat through SIP.

SIP also requires proxy and registrar network elements to work as a practical service. Although two SIP endpoints can communicate without any intervening SIP infrastructure (which is why the protocol is described as peer-to-peer), this approach is impractical for a public service. There are various softswitch implementations (by Nortel, Sonus and many more) which can act as proxy and registrar. Other companies, led by Ubiquity Software and Dynamicsoft have implemented products based on the proposed standards, building on the Java JAIN specification.

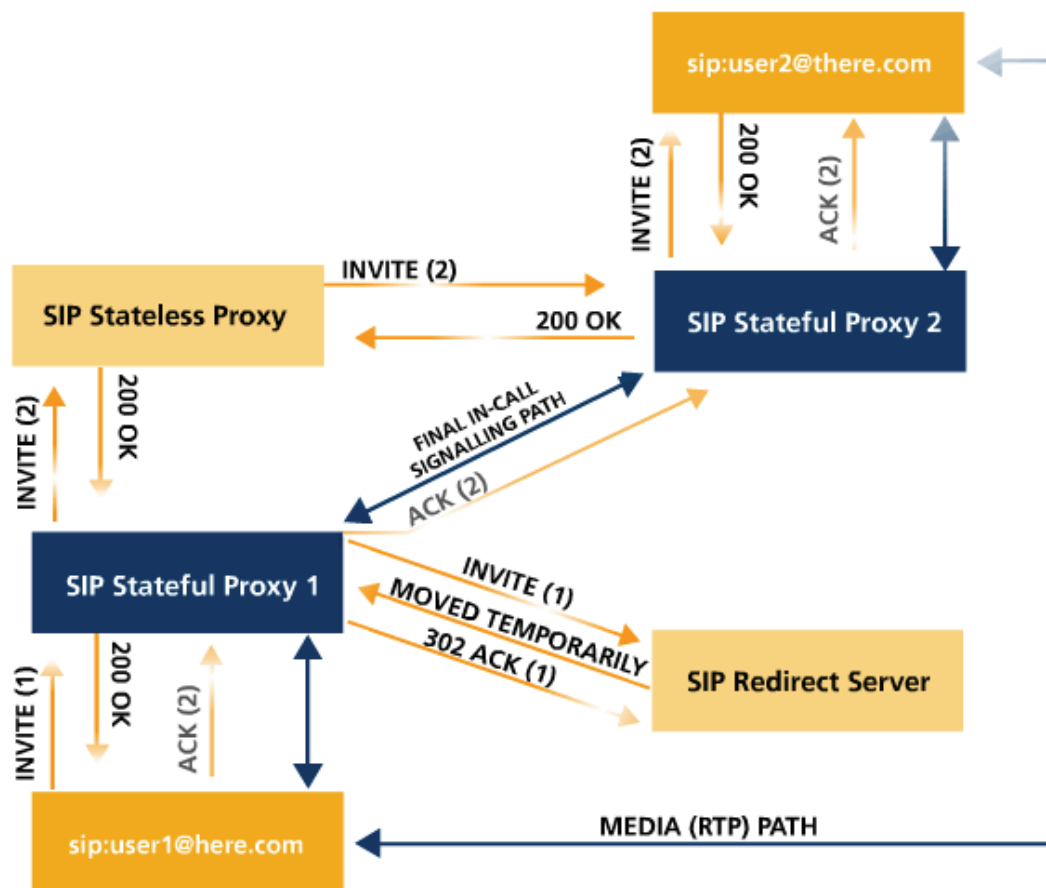

### Instant messaging (IM) and presence

A standard instant messaging protocol based on SIP, called SIMPLE, has been proposed and is under development. SIMPLE can also carry presence information, conveying a person's willingness and ability to engage in communications. Presence information is most recognizable today as buddy status in IM clients such as MSN Messenger and AIM.



## Sending faxes in real-time over an IP network

Some efforts have been made to integrate SIP-based VoIP with the XMPP presence specification used by Jabber. Most notably Google Talk, who has extended XMPP to integrated voice, plans to integrate SIP. Gizmo Project, who has implemented SIP, has integrated XMPP in their client and service.

### Commercial application

The Real-time Transport Protocol (RTP) used to carry the media stream does not traverse NAT routers. Most SIP clients can use STUN to traverse full cone, restricted cone, and port restricted cone NAT but not symmetrical NAT. Also some newer routers now recognize and pass SIP traffic. RTP Proxies, special purpose SIP line speed processors analogous to HTTP proxies commonly used in the early 1990s, enable CALEA and traversal of older, SIP-unaware NAT devices.

As envisioned by its originators, SIP's peer-to-peer nature does not enable network-provided services. For example, the network can not easily support legal interception of calls (referred to in the United States by the law governing wiretaps, CALEA). Emergency calls (calls to E911 in the USA) are difficult to route. It is difficult to identify the proper Public Service Answering Point, PSAP because of the inherent mobility of IP end points and the lack of any network location capability. However, as commercial SIP services begin to take off practical solutions to these problems are being proven. Standards being developed by such organizations as 3GPP and 3GPP2 define applications of the basic SIP model which facilitate commercialization and enable support for network-centric capabilities such as CALEA.

Companies such as Vonage and SIPphone were consumer SIP pioneers and have a fast growing subscriber base. Major carriers like AT&T and Level (3) are now following suit. The traditional telecommunications industry (including companies such as Lucent Technologies and Nortel) is now focused on developing systems based on the architecture model and SIP extensions as defined by 3GPP in their IP Multimedia Subsystem (IMS).

Some VoIP phone companies, such as BroadVoice, allow customers to bring their own SIP devices, including SIP-capable telephone sets, the Asterisk PBX, or softphones. The new market for consumer SIP devices continues to expand.

The open source community started to provide more and more of the SIP technology required to build both end points as well as proxy and registrar servers leading to a commoditization of the technology, which accelerates global adoption. SIPfoundry has made available and actively develops a variety of SIP stacks, client applications and SDKs, in addition to entire IP PBX solutions that compete in the market against mostly proprietary IP PBX implementations from established vendors.

### FAXmaker and Fax over IP (FoIP)

The GFI FAXmaker Fax Server can send faxes over IP by using IP-enabled software or devices. These can be any one of the following:

- **Dialogic (Eicon) Networks** – Eicon Diva Server SoftIP. (software)
- **Brooktrout Technology** – Brooktrout TR1034+##-##-1N boards. (hardware)

For best reliability of faxes of IP you have to use a VoIP service or gateway that is T.38 capable. Emphasis on the T.38 part, this is a must. We have only tested one gateway device which is a Cisco 2800 series router with IOS version 12.3 (8) T3.



## Sending faxes in real-time over an IP network

### About GFI

GFI is a leading software developer that provides a single source for network administrators to address their network security, content security and messaging needs. With award-winning technology, an aggressive pricing strategy and a strong focus on small-to-medium sized businesses, GFI is able to satisfy the need for business continuity and productivity encountered by organizations on a global scale. Founded in 1992, GFI has offices in Malta, London, Raleigh, Hong Kong, and Adelaide which support more than 200,000 installations worldwide. GFI is a channel-focused company with over 10,000 partners throughout the world. GFI is also a Microsoft Gold Certified Partner. More information about GFI can be found at <http://www.gfi.com>.



### Sign up to GFI's FREE SMB-Zone Newsletter

Receive FREE invites to SMB focused content such as IT Advice,  
Topical White Papers, MVP Tips and Tricks, Webcasts and much more!

© 2009 GFI Software. All rights reserved. The information contained in this document represents the current view of GFI on the issues discussed as of the date of publication. Because GFI must respond to changing market conditions, it should not be interpreted to be a commitment on the part of GFI, and GFI cannot guarantee the accuracy of any information presented after the date of publication. This White Paper is for informational purposes only. GFI MAKES NO WARRANTIES, EXPRESS OR IMPLIED, IN THIS DOCUMENT. GFI, GFI EndPointSecurity, GFI EventsManager, GFI FAXmaker, GFI MailEssentials, GFI MailSecurity, GFI MailArchiver, GFI LANGuard, GFI Network Server Monitor, GFI WebMonitor and their product logos are either registered trademarks or trademarks of GFI Software Ltd. in the United States and/or other countries. All product or company names mentioned herein may be the trademarks of their respective owners.